

DOI: <https://doi.org/10.15407/rpra28.01.071>
UDC 621.372.8; 621.317

**A.E. Kogut¹, I.K. Kuzmychov¹, G. Annino², R.S. Dolia¹,
S.O. Nosatiuk¹, E.A. Kogut³, V.N. Derkach¹, and Ye.N. Ostryzhnyi¹**

¹O.Ya. Usikov Institute for Radiophysics and Electronics NAS of Ukraine
12, Acad. Proskury St., Kharkiv, 61085, Ukraine
E-mail: hazar70@gmail.com

²Istituto per i Processi Chimico Fisici del Consiglio Nazionale delle Ricerche
Viale Ferdinando Stagno d'Alcontres, n. 37, Messina 98158, Italia
E-mail: giuseppe.annino@yahoo.it

³V.N. Karazin National University of Kharkiv
4, Svobody Sq., Kharkiv, 61022, Ukraine

OMNIDIRECTIONAL MILLIMETER-WAVELENGTH ANTENNAS BASED ON SEGMENTAL DIELECTRIC RESONATORS WHICH SUPPORT WHISPERING GALLERY MODES

Subject and Purpose. The subject of investigation is a new class of resonant-type transmit antennas intended for operation at millimeter wavelengths. The model under consideration is based on the idea of diffractive re-emission of waves into the azimuthal direction by local inhomogeneities of the basically cylindrical structure. The purpose of the work is to justify the possibility of using such an effect for creating antennas with a circular radiation pattern, and to suggest an appropriate design.

Methods and Methodology. The research program included both experimental work and application of advanced computer simulation techniques. The modern methods employed have allowed studying electromagnetic field distributions both in internal domains of the dielectric resonators and in the far-field zones of the resonator-based antennas.

Results. Design solutions have been proposed for resonant-type, omnidirectional transmit antennas to operate in the millimeter waveband. The characteristic parameters are sizes of their radiating elements, specifically the segmental members equidistantly disposed along the azimuthal direction on the cylindrical surfaces of dielectric disks. The radiational characteristics of such antennas, with segments of either localized or extended dimension (compared with the operating wavelength) have been investigated. Electric field intensity distributions in the far-field region and the respective gain factors of the antennas have been studied.

Conclusions. The antennas based on segmental dielectric resonators have been shown to form multi-lobe radiation patterns covering the angular sector of 0–360° along the azimuth. By placing the local segments at the resonant field's antinodes (of the operating mode) it is possible to achieve relatively high values of the gain, reaching 15.5 dB at the lobe maxima.

Keywords: segmental dielectric resonators, millimeter-wave omnidirectional antennas, whispering gallery modes.

Citation: Kogut, A.E., Kuzmychov, I.K., Annino, G., Dolia, R.S., Nosatiuk, S.O., Kogut, E.A., Derkach, V.N., and Ostryzhnyi, Ye.N., 2023. Omnidirectional millimeter-wavelength antennas based on segmental dielectric resonators which support whispering gallery modes. *Radio Physics and Radio Astronomy*, **28**(1), pp. 71–79. <https://doi.org/10.15407/rpra28.01.071>

Цитування: Когут О.Є., Анніно Г., Кузьмичов І.К., Доля Р.С., Носатюк С.О., Когут Є.О., Деркач В.М., Остріжний Є.М. Антени кругового огляду для міліметрового діапазону довжин хвиль на основі сегментарних діелектричних резонаторів з модами шепочучої галереї. *Радіофізика і радіоастрономія*. 2023. Т. 28. № 1. С. 71–79. <https://doi.org/10.15407/rpra28.01.071>

© Publisher PH "Akademperiodyka" of the NAS of Ukraine, 2023. This is an open access article under the CC BY-NC-ND license (<https://creativecommons.org/licenses/by-nc-nd/4.0/>)

© Видавець ВД «Академперіодика» НАН України, 2023. Статтю опубліковано відповідно до умов відкритого доступу за ліцензією CC BY-NC-ND (<https://creativecommons.org/licenses/by-nc-nd/4.0/>)

Introduction

The development of modern millimeter-wave technologies for such applied areas as telecommunication systems, 5G networks, radar, and data transmission systems requires creation of an adequate element base and search of solutions for new technical problems [1–7]. The devices with frequency selective properties have a particular significance for the microwave technology as they offer solutions to problems of electromagnetic compatibility or safety, as well as creation of transmission channels for discrete signals. The principle of operation of such devices is based upon the use of a variety of resonant systems. The dielectric resonators operating with higher-order modes are among the most attractive solutions, characterized by high Q -factors and rarefied modal spectra.

Let us consider the operating principle of the dielectric resonators (DRs) supporting higher-order azimuthal oscillations. Such oscillations are known in the literature as whispering gallery modes, by analogy with the acoustic modes that exist in circular closed structures and are characterized by extremely low attenuation [8–14].

The acoustic principle of the whispering gallery is widely used in electromagnetism. For instance, it underlies operation of the DRs formed by a disk or a ball. The electromagnetic whispering gallery modes (WGMs) in such resonators are formed by waves incident on their inner curvilinear surfaces at very small angles. This determines fulfillment of the total internal reflection condition which is necessary for accumulation of electromagnetic energy inside the dielectric structure. Since the reflection coefficient from the inner surface of an open dielectric structure is close to unity, radiation losses are extremely small. For this reason, the DRs with operating WGMs have a high unloaded Q -factor whose magnitude is determined mainly by losses in the resonator material.

The resonant fields of the WGMs are localized mainly inside the dielectric material near the curved surface of the resonator, being bounded by internal (from the side of the dielectric) and external (from the side of free space) caustic surfaces. The brighter spots of the WGM field distributions are similar to the petals observable along the curved surface of the resonator (Fig. 1). At present, the theory of dielectric resonators supporting WGMs is well developed. An-

alytical expressions have been derived for the spectral and power characteristics of the DRs, modal compositions of internal fields in the resonators and frequency ranges of resonator operability with given geometric parameters.

The dielectric disk is the simplest and most convenient model for calculating WGM characteristics in DRs. It is characterized by improved spectral characteristics and a relatively high Q -factor [11, 15].

The DRs of disk-like geometry that support WGMs have found broad areas of application relating to creation of various active and passive millimeter-wave devices, including filters, solid-state oscillators, power combiners and instruments for measuring electric properties of dielectrics [12, 16–22].

In this paper a new field of application is proposed for the WGM-supporting dielectric resonators, namely for the development of omnidirectional millimeter-wavelength antennas for all-round surveillance.

Antennas: design solutions and performance

now we focus on the special feature of the WGM fields in the disk-like DRs which may allow a significant expansion of the application area for the resonators. Fig. 1 shows the resonant fields of the WGMs to be localized near the curved surface of the disk resonator and distributed symmetrically in the 0° – 360° sector of azimuthal angles.

These are the reasons why such DRs are promising structures for creating antennas with a circular field of view. Still, the low level of radiation into the surrounding space that has been mentioned remains the principal disadvantage of such emitting structures.

In this paper, we suggest an original approach to creating efficient emitting antennas based on WGM which employ dielectric disks. The operating principle of the antennas proposed exploits electromagnetic wave diffraction by the localized non-uniformities that are distributed periodically along the azimuthal direction at the curved surface of the dielectric disk. An efficient radiation of the resonant field from the disk-based structure can be achieved due to radially oriented slits dividing its curvilinear surface into separate segments (Fig. 2, *a*). Radiation from the segmental dielectric structure occurs owing to diffraction of the whispering gallery modal fields

by the segment faces. The width of each segment is dictated by the size of the area of a single field variation, such that field antinodes of opposing phases (0 and π) shall get placed at the faces of each segment (Fig. 2, *b*). This determines the highest E -field intensity on the emitting elements of the antenna, i.e., segment faces. The slits are cut to such a depth as to be close to the internal caustic surface of an operating WGM. The number of the segments and the disk diameter, being the principal parameters of the segmental DR, are determined by the choice of its operating WGM (hence, of the frequency).

In this paper, an antenna based on the segmental DR made of Teflon $\epsilon' = 2.08$ with a diameter of 80 mm is considered. It contains 36 segments, which determines choosing the operating WGM with 36 field variations along the azimuthal coordinate. The segments have a trapezoidal shape with the largest width of 5.5 mm at the border of the dielectric structure. All cuts have a width of 1.5 mm and a deep of 8 mm.

The correct choice of the supply element feeding electromagnetic power from an external source to the antenna, as well as the amount of matching between its impedance and field impedances of the operating WGMs in the DR, its location and orientation, are all of crucial importance for achieving a high efficiency of radiation. The use of a localized coupling element,

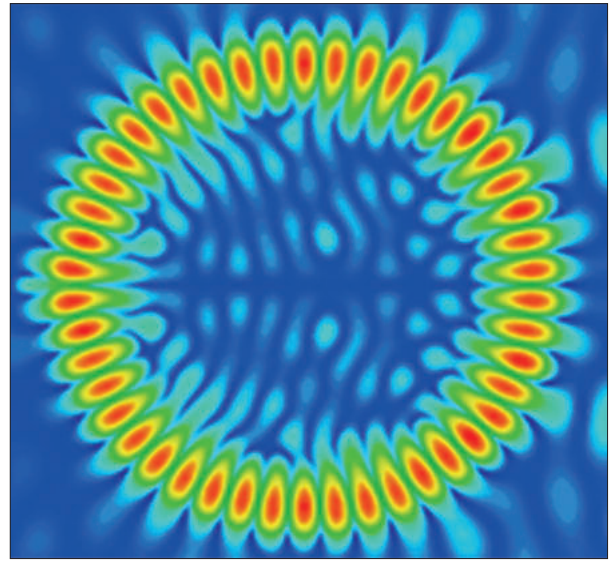

Fig. 1. The resonant fields of WGMs in a disc-shaped DR

such as a slot, might be a suitable solution. Such an element is able to produce strong electromagnetic coupling of the antenna to an external source, thus providing for an efficient power supply [19, 20]. This method of feeding the antenna is realized by placing the segmental dielectric structure on the plane conducting mirror (made of copper) that involves the coupling slot. The rectangular coupling slot is represented by a tapered ($7.2 \text{ mm} \times 0.5 \text{ mm}$ in size) open end of the standard ($7.2 \text{ mm} \times 3.4 \text{ mm}$) metal

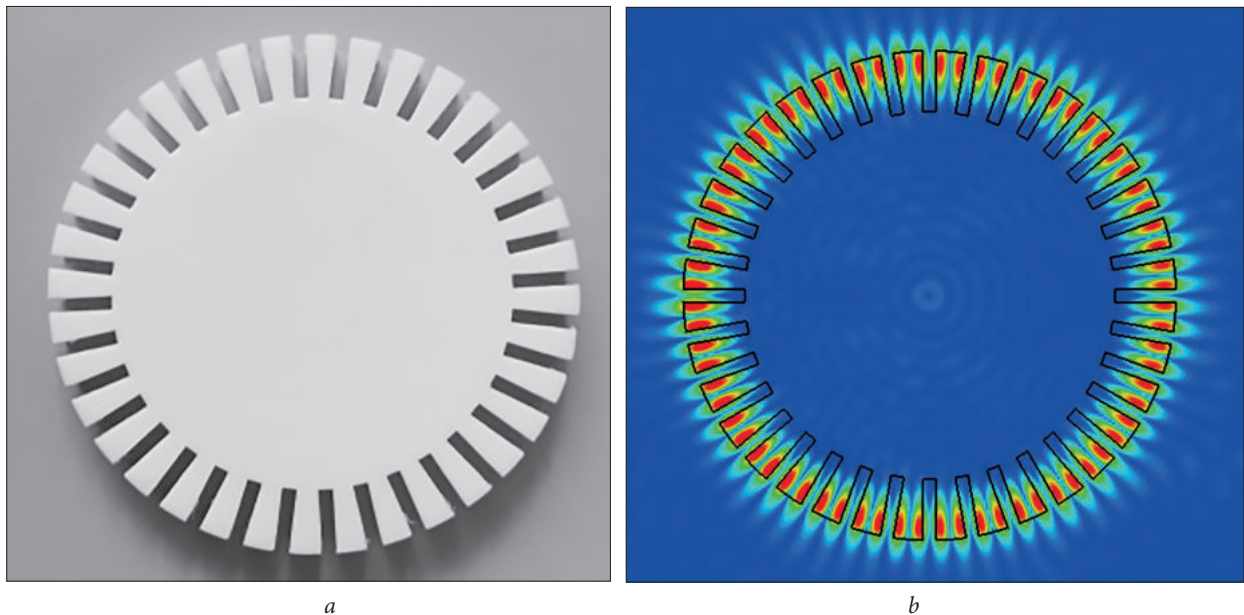

Fig. 2. The segmental DR, a basic structure for the omnidirectional emitting antenna (*a*), and its representative WGM field distribution (*b*)

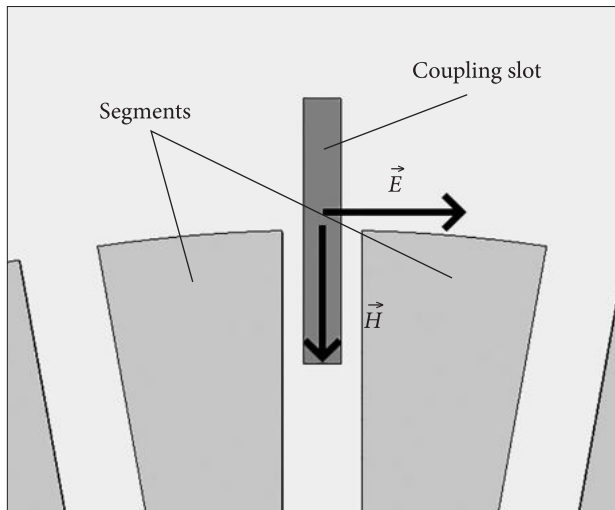

Fig. 3. The coupling slot in the segmental DR intended for exciting operative WGMs

waveguide placed in the narrow air gap between two adjacent segments (Fig. 3). The wider side of the coupling slot is parallel to segment faces, which arrangement ensures excitation of *HE*-polarized WGMs in the segmental DR. By placing the coupling slot in the narrow air gap one can ensure its closest position with regard to two adjacent antinodes of the resonant *E*-field (Fig. 2, *b*), thus providing for efficient excitation of the operating WGM in the segmental DR.

It should be noted that the use of the coupling slot as a WGM exciter results in appearance of a standing wave in the segmental DR, as the waves emitted travel in opposite directions inside the resonator. Their interference leads to appearance of spatially stable antinodes and field nodes. The principal features of the antenna proposed are the multi-lobe radiation pattern and the high far-field intensity of the *E*-field in each lobe. The high efficiency of the radiation process is ensured at certain fixed frequencies determined by the proper resonant characteristics of the dielectric structure.

Fig. 4, *a* presents results of an experimental study (with the use of a receiving horn) of the antenna gain at a resonant frequency of 36.08 GHz, as distributed along the azimuthal coordinate. In the experiment the receiving horn antenna was moved along the azimuthal coordinate in the angular sector of 0–360°, with a step of 0.01°. The received signal was amplified by a selective amplifier and recorded in a digital voltmeter, in the capacity of an estimate for the *E*-field intensity in the far-field region of the antenna.

The weak ("shadow") field area in the angular sector of 170°–190° is due to the presence of a coupling slot at 180°. The slot is a localized non-uniformity that perturbs the field distribution, thus leading to displacement of the *E*-field antinodes from the segment faces. To reduce this negative effect, it is proposed to use two coupling slots, placing them symmetrically relative each other (at an angle of 180°). This makes it possible to perform a correction of the modal field distributions in the segmental DR, obtaining an almost uniformly distributed antenna gain in the lobes (Fig. 4, *b*). As can be seen from Fig. 4, the proposed antenna forms a 72-lobe radiation pattern. The width of each lobe at a –3 dB level is about 3.5°. The antenna gain reaches relative magnitudes like 12 dB in the lobes. It has been found in experiment that the antenna pattern width in the elevation-angle plane is about 10°.

To increase the *E*-field intensity near emitting elements of the antennas under consideration we can resort to a different design of the segmental DRs, making the number of segments correspond to the number of resonant field antinodes (with field phases 0 and π). Apparently, the radiating efficiency of such antennas should be better.

We will consider now a segmental DR of 68 segments made of Teflon ($\epsilon = 2.08$) on a copper substrate (mirror). The outer diameter and height of the DR are $D_1 = 64.8$ mm and $H = 6.5$ mm, respectively (Fig. 5).

The radially-oriented cuts into the dielectric structure that are distributed uniformly along its curved surface produce 68 segments of trapezoidal form. Each of the segments is disposed so that its wider part (of width $L_1 = 1.64$ mm) lies at the outer boundary of the structure. The neighboring segments are separated by air gaps of width $L_2 = 1.35$ mm and depth $h = 9$ mm. The depth is chosen so that the gaps should not approach too closely to the internal caustic surface whose location can be calculated from the analytical expressions of paper [7]. The segmental DR contains in its central part a concentric cavity of diameter $D_2 = 43.2$ mm. with the edges coated with a reflective layer (electric conductor, specifically copper). This is done in order to increase the resonant field intensity in apertures of the antenna's emitting elements (segments). The size of the cavity is selected so that the internal caustic surface of the WGM fields should be localized in the air. As follows from calcu-

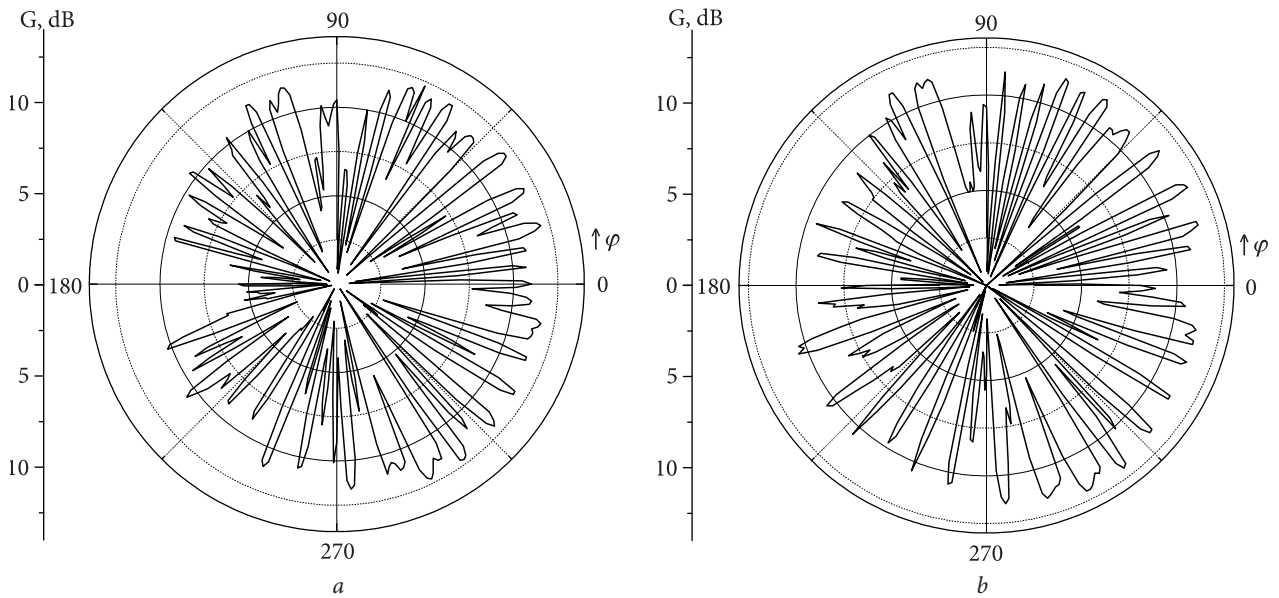

Fig. 4. Behavior of antenna gain at resonant frequency 36.08 GHz along an azimuthal coordinate at using one (a) and two (b) coupling slots

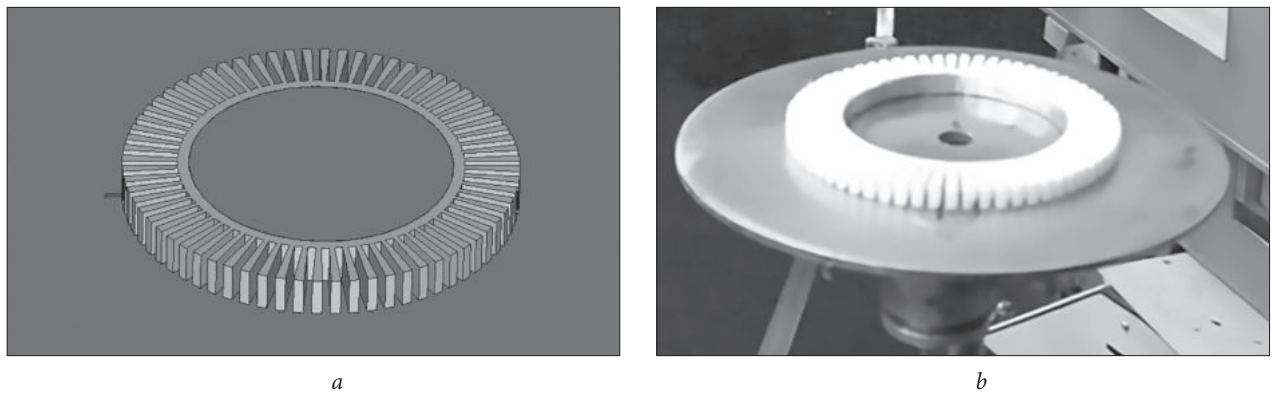

Fig. 5. Segmented DR with 68 emitting segments at simulation (a) and at experiment (b)

lations, that would allow obtaining the highest field intensity in each emitting segment of the antenna.

The excitation of WGMs in the segmental DR is carried out by means of coupling it to a source, such as an open end of a rectangular metal waveguide, tapered along the narrow wall (cross section 7.2×3.4 mm). For convenience of design and optimization of power supply conditions to the antenna, the segmented DR is placed on a planar copper mirror of circular geometry (110 mm in diameter, see Fig. 5). The coupling element, represented by a rectangular open end of the feeding waveguide, 7.2×1.0 mm in size, is connected to the mirror through a circular hole. The coupling slot is located at the center of the air gap between two adjacent segments and oriented parallel to their faces. The arrangement provides the

best impedance matching between the coupling element and the resonator.

The essential parameters of the segmental DR-based antenna, such as radiation pattern and reflection coefficient from the input, are measured within the frequency range of 30.0 to 45.0 GHz with an automated measuring complex.

Shown in Fig. 6 is the S_{11} -parameter (reflection coefficient) of the antenna within the range of 30.0 to 50.0 GHz.

The figure shows a series of resonant responses corresponding to WGMs with different azimuthal indexes n . The resonance with the highest amplitude at a frequency $f \approx 40.5$ GHz corresponds to the operating mode $n = 34$. The number of opposite-phased (0 and π) field antinodes of this mode corresponds to

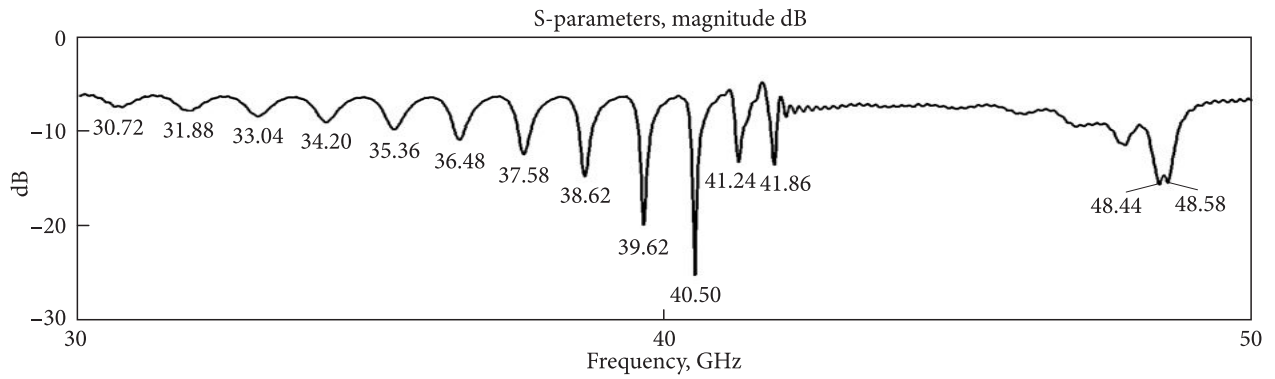

Fig. 6. The S_{11} -parameter of the 68-segment DR-based antenna over the frequency range 30.0–50.0 GHz

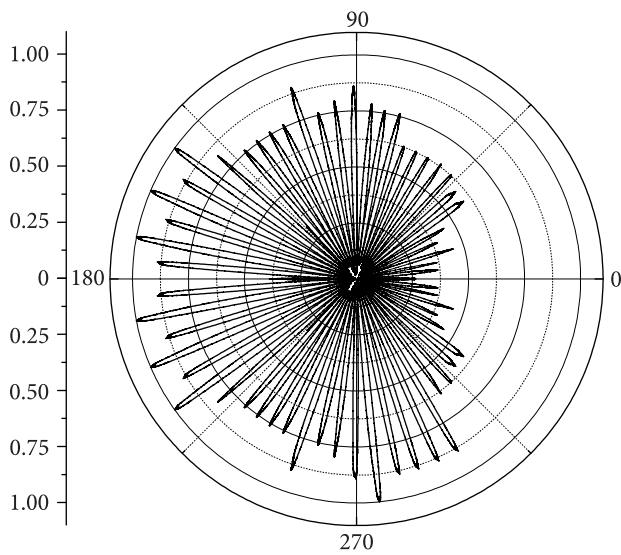

Fig. 7. The radiation pattern of a 68-segment DR-based antenna at a 40.56 GHz frequency

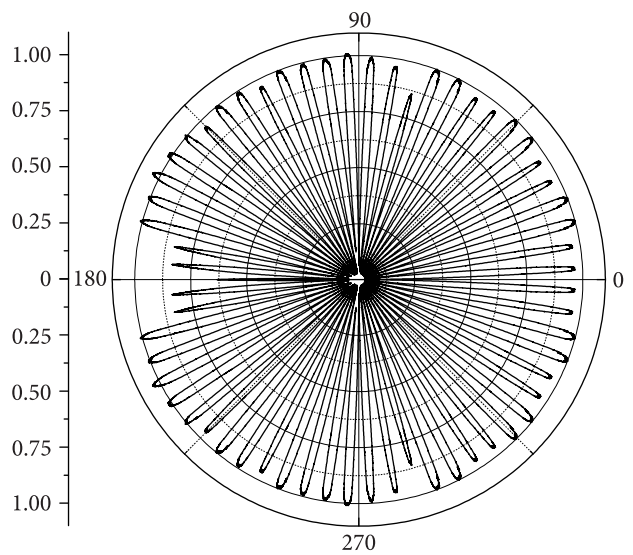

Fig. 8. The radiation pattern of a 68-segment DR-based antenna fed via two coupling slots

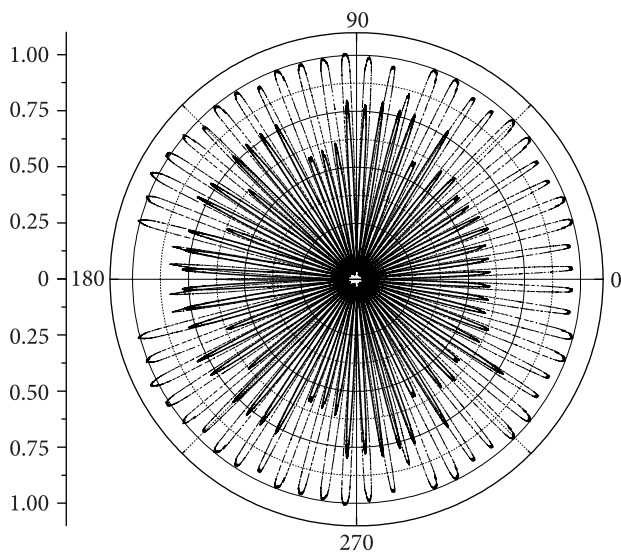

Fig. 9. The radiation patterns of a 68-segment DR-based antenna, shown for operating frequencies of 40.56 GHz (dotted line) and 40.51 GHz (solid line)

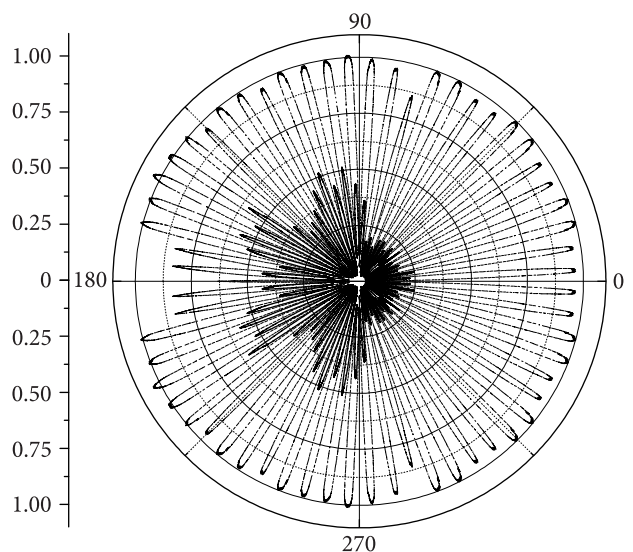

Fig. 10. The radiation patterns of a 68-segment DR-based antenna, shown for operating frequencies of 40.56 GHz (dotted line) and 40.46 GHz (solid line)

the number of resonator segments, namely 68 units (Fig. 5). The modes with other values of the azimuthal index are characterized by a shift in the position of their resonant antinodes relative the segments. For this reason, the efficiency of their excitation, which can be estimated through amplitude characteristics, is lower in comparison with the operating WGM ($n = 34$).

As follows from the above analysis, the principal operating frequency of the antenna under consideration is $f \approx 40.5$ GHz. Our experimental studies have shown the highest far-field intensity of the radiated E -component, averaged over the angular sector 0 – 360° , to be achievable at the frequency of 40.56 GHz.

Fig. 7 shows the radiation pattern of the antenna (in relative units) within angular sectors of 0 – 180° and 180 – 360° along the azimuth. Note the E -field strength to be of different magnitudes in different lobes of the radiation pattern. The angular sectors of 0 to 30° and 330 to 360° are kind of "shadow" regions characterized by comparatively low field strengths in the pattern lobes. It is well in this sector (specifically, at the azimuthal angle 0°) that the coupling slot has been placed. In its capacity of a localized inhomogeneity the coupling slot exerts a notable perturbation on the resonant field of the operative WGM. As a result, the field antinodes are shifted with respect to the segments within the angular sectors 0 – 30° and 330 – 360° .

By analogy with the above discussed case of a 36-segment antenna, correction of the field distribution in the segmental DR, aimed at obtaining uniformly distributed field peaks in the segments, can be achieved by symmetrically placing two coupling slots. The other coupling slot of the same dimensions is to be placed on the metal mirror of the antenna, from the opposite side of the segmental dielectric structure (at the point with the azimuthal coordinate 180°). The two coupling slots are powered from a common external source via a directional coupler. Phase synchronization of the signals at the antenna inputs is provided by a phase shifter introduced in the circuit of one of the coupling slots.

The radiation pattern for 40.56 GHz of an antenna employing two coupling slots is shown in Fig. 8. As can be seen from the Figure, the use of two symmetrically arranged coupling slots provides for modal correction in the segmental DR, ensuring a nearly uniform distribution of the E -field intensity in the

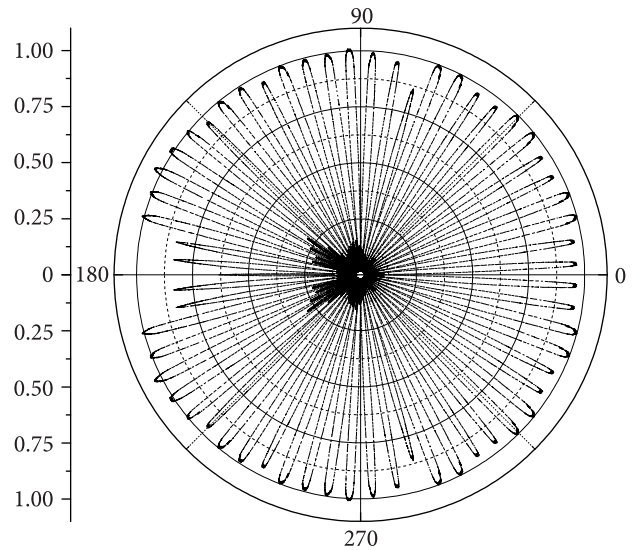

Fig. 11. The radiation patterns of a 68-segment DR-based antenna, shown for operating frequencies of 40.56 GHz (dotted line) and 40.06 GHz (solid line)

radiation pattern lobes. The width of each of them at the -3 dB level is about 4° .

The high gain values shown at the resonance frequency of the segmental DR by the pattern lobes are the principal advantage of the proposed antenna. As has been found, the gain can reach 15.5 dB. The magnitude as high as this is determined by the high E -field intensity existing in the radiative area near the emitting segments. Meanwhile, Fig. 6 representing the S -parameter of the segmental DR-based antenna shows the resonant response of the operating WGM at 40.56 GHz to correspond to a low Q -factor of the DR. The loaded Q -factor of the 68-segment DR under consideration has been measured as $Q \approx 250$. The Q -factor as low as this apparently is due to the high radiative losses via the air gaps. The corresponding bandwidth at a -3 dB level is about 160 MHz.

The above data on the radiating properties of the antenna (Figs. 7 and 8) relate to the central resonant frequency of the segmental DR. Fig. 9 shows the radiation pattern of the proposed antenna (solid line) with a 50 MHz offset of the reference signal fed into the antenna with respect to the 40.56 GHz central resonance. The frequency of 40.51 GHz is within the resonant area. For comparison, the dotted line in Fig. 9 shows the antenna pattern at the central resonance frequency of the segmental DR. As can be seen, the form of the radiation pattern at 40.51 GHz is not significantly different as compared with the pattern form shown by the antenna at its operating

frequency. It is characterized by somewhat lower magnitudes of the gain. Say, with the reference frequency set off by 50 MHz, the gain values within the lobes are, on average, 12.7 dB.

Should the reference frequency fed into the antenna fall outside the resonant area, the form of the radiation pattern might change significantly. With a reference signal detuned by 100 MHz relative to the operating frequency of the antenna ($f = 40.46$ GHz), the multi-petal form of the radiation pattern is preserved only in the azimuthal angle sectors of 90° to 180° and 180° to 270° (see Fig. 10). Accordingly, the gain magnitudes shown within the petals at the offset frequency are significantly lower than the 6.8 dB value for the operating frequency. Over the rest of the angular sector, the level of power radiated by the antenna is an order of magnitude lower than such at the main operating frequency.

At greater values of frequency detuning, the radiative properties of the antenna are almost totally deteriorated. By way of example, consider results of the measurements carried out with the reference frequency detuned by 500 MHz relative the operating frequency of the antenna (Fig. 11). The reason for the poor radiative efficiency is the lack of electromagnetic field energy stored in a segmental dielectric structure at its resonant frequencies. The appearance of individual lobes with a low E -field intensity is asso-

ciated with occasional wave reflections from individual segments. Such waves may happen to be emitted by the coupling slots and propagate along the plane surface of the metal mirror.

Conclusion

The diffraction radiation effect has been established for whispering gallery modes excited by periodic non-uniformities in dielectric segmental resonant structures.

It has been shown that the principal sphere of application for the effect is development of multi-lobe omnidirectional millimeter-wavelength antennas. The devices proposed combine the advantages pertinent to resonant systems, like selective frequency response and high efficiency of mode excitation, with the useful properties of antennas with a broad radiation pattern.

The main advantage of the antennas in question is the relatively high gain value demonstrated in the lobes at resonant frequencies. The favorable emitting properties of the antenna are preserved within frequency bands of several tens of megahertz.

The results obtained can become an important contribution to the development of advanced communication technologies in the millimeter and sub-millimeter wave bands (terahertz frequencies).

REFERENCES

1. Rayleigh, J.W. Strutt, 1896. On the Whispering Galleries. In: Theory of Sound. London: Macmillan Publ. Vol. 2, pp. 127–129.
2. Rayleigh, J.W. Strutt, 1910. The Problem of the Whispering Gallery. *Phil. Mag.*, **20**, pp. 1001–1004.
3. Lin, G., and Chembo, Ya.K., 2016. Opto-acoustic phenomena in whispering gallery mode resonators. *Int. J. Optomechanics*, **10**(1), pp. 32–39.
4. Ye, Ming-Yong, Shen, Mei-Xia, Lin, Xiu-Min, 2016. Ringing phenomenon-based whispering-gallery-mode sensing. *Sci. Rep.*, **6**(1), pp. 1–7.
5. Vedrenne, C., Arnaud, J., 1982. Whispering-Gallery modes in dielectric resonators. *IEE Proc., H Microw. Opt. Antennas*, **129**(4), pp. 183–187.
6. Annino, G., Cassettari, M., Longo, I., Martinelli, M., 1997. Whispering gallery modes in a dielectric resonator: characterization at millimeter wavelength. *IEEE Trans. Microwave Theory Tech.*, **45**(11), pp. 2025–2034.
7. Annino, G., Cassettari, M., Martinelli, M., 2002. Study on planar whispering gallery dielectric resonators. I. General properties. *Int. J. Infrared Millimeter Waves*, **23**, pp. 597–615.
8. Annino, G., Cassettari, M., Martinelli, M., 2002. Study on planar whispering gallery dielectric resonators. II. A multiple-band device. *Int. J. Infrared Millimeter Waves*, **23**, pp. 617–634.
9. Wait, J.R., 1967. Electromagnetic Whispering Gallery Modes in a Dielectric Rod. *Radio Sci.*, **2**, pp. 1005–1017.
10. Il'chenko, M.E., Vziatyshchev, V.F., Gassanov, L.G., 1989. *Dielectric resonators*. Moscow: Radio i svyaz' Publ. (in Russian).
11. Kirichenko, A.Ya., Prokopenko, Yu.V., Filippov, Yu.F., Cherpak, N.T., 2008. *Quasioptical solid-state resonators*. Kiev: Naukova Dumka Publ. (in Russian).
12. Lee, J., Pinel, S., Laskar, J., and Tentzeris, M.M., 2007. Design and Development of Advanced Cavity-Based Dual-Mode Filters Using Low-Temperature Co-Fired Ceramic Technology for V-Band Gigabit Wireless Systems. *IEEE Trans. Microwave Theory Tech.*, **55**(9), pp. 1869–1879.
13. Jiao, H., Guillon, P., Bermudez, L.A., Auxemery, P., 1987. Whispering-gallery mode of dielectric structures: application to millimeter wave band stop filters. *IEEE Trans. Microwave Theory Tech.*, **35**(12), pp. 1169–1175.

14. Dick, G.J., Saunders, J., 1990. Measurement and analysis of a microwave oscillator stabilized by a sapphire dielectric ring resonator for ultra-low noise. *IEEE Trans. Ultrason. Ferroelectr. Freq. Control.*, **37**(5), pp. 339–346.
15. Kharkovsky, S., Kirichenko, A., Kogut, A., 1996. Solid-state oscillators with whispering-gallery-mode dielectric resonators. *Microw. Opt. Technol. Lett.*, **12**(4), pp. 210–213.
16. Kogut, A.E., Eremenko, Z.E., Kuzmichev, I.K., Dolia, R.S., Islam, M.T., 2019. Power Summation of the Gunn-Diodes in the Ultra-Thin Planar Dielectric Resonator. In: *2019 49th European Microwave Conference (EuMC)*. Paris, France, 01–03 Oct. 2019, pp. 336–339. IEEE Publ. DOI: 10.23919/EuMC.2019.8910948.
17. Krupka, J.A., Tobar, M.E., Hartnett, J.G., Cros D., Le Floch, J.-M., 2005. Extremely high-Q factor dielectric resonators for millimeter-wave applications. *IEEE Trans. Microwave Theory Tech.*, **53**(2), pp. 702–712.
18. Eremenko, Z., Kogut, A., Shubnyi, A., Dolia, R., 2019. Comparison of High Loss Liquid Dielectric Properties Measurement Using Waveguide and Resonator Methods. In: *2019 European Microwave Conference in Central Europe (EuMCE)*. Prague, Czech Republic, 13–15 May 2019. IEEE Publ.
19. Popov, E. ed., 2012. *Gratings: Theory and Numeric Applications*. AMU (PUP).
20. Aveline, D.C., Baumgartel, L.M., Lin, G., and Yu, N., 2013. Whispering gallery mode resonators augmented with engraved diffraction gratings. *Opt. Lett.*, **38**(3), pp. 284–286.
21. Huy, K.P., Morand, A., and Benech, P., 2005. Modelization of the Whispering Gallery Mode in Microgear Resonators Using the Floquet–Bloch Formalism. *IEEE J. Quantum Electron.*, **41**(3), pp. 357–365.
22. Nozaki, K., Nakagawa, A., Sano, D., and Baba, T., 2003. Ultralow Threshold and Single-Mode Lasing in Microgear Lasers and Its Fusion With Quasi-Periodic Photonic Crystals. *IEEE J. Sel. Top. Quantum Electron.*, **9**(5), pp. 1355–1360.

Received 11.11.2022

О.Є. Козут¹, І.К. Кузьмичов¹, Г. Анніно², Р.С. Доля¹,
С.О. Носатюк¹, Є.О. Козут³, В.М. Деркач¹, Є.М. Остріжний¹

¹ Інститут радіофізики та електроніки ім. О.Я. Усикова НАН України
вул. Акад. Проскури, 12, м. Харків, 61085, Україна
E-mail: hazar70@gmail.com

² Istituto per i Processi Chimico Fisici del Consiglio Nazionale delle Ricerche
Viale Ferdinando Stagno d'Alcontres, n. 37, Messina 98158, Italia
E-mail: giuseppe.annino@yahoo.it

³ Харківський національний університет імені В.Н. Каразіна
майдан Свободи, 4, м. Харків, 61022, Україна

АНТЕНИ КРУГОВОГО ОГЛЯДУ ДЛЯ МІЛІМЕТРОВОГО ДІАПАЗОНУ ДОВЖИН ХВИЛЬ НА ОСНОВІ СЕГМЕНТАРНИХ ДІЕЛЕКТРИЧНИХ РЕЗОНАТОРІВ З МОДАМИ ШЕПОЧУЧОЇ ГАЛЕРЕЇ

Предмет і мета роботи. Предметом роботи є новий клас випромінювальних антен резонансного типу для міліметрового діапазону довжин хвиль. В основу моделі, що розглядається, покладено ідею про дифракційне перевипромінювання хвиль в азимутальному напрямку локальними неоднорідностями циліндричної структури антени. Отже, метою роботи є обґрунтування та використання цього ефекту для створення антенних приладів із круговою діаграмою направленості та вибір відповідної конструкції.

Методи та методологія. Дослідження проведено як експериментальним шляхом, так і за допомогою сучасних методів комп'ютерного моделювання. Використано сучасні методи дослідження розподілу електромагнітних полів як у власному просторі діелектричних резонаторів, так і в дальніх зонах антен на їхній основі.

Результати. Представлено конструкції випромінювальних антен резонансного типу для кругового огляду в міліметровому діапазоні довжин хвиль. Їхніми відмінними параметрами є розміри випромінювальних елементів, а саме сегментів, що є еквідистантно розташованими в азимутальному напрямку на циліндричній поверхні діелектричних дисків. Досліджено випромінювальні характеристики антен з локальними та протяжними, порівняно з робочою довжиною хвилі, сегментами. Вивчено розподіли напруженості електричного поля в дальній зоні антен та їхні відповідні коефіцієнти підсилення.

Висновки. Показано, що антени на основі сегментарних діелектричних резонаторів формують багатопелюсткові діаграми направленості в азимутальному секторі кутів 0...360°. Використання локальних сегментів, розміщених у пучностях резонансного поля робочої моди, дозволяє отримати відносно високі значення коефіцієнта підсилення, котрі в пелюстках можуть сягати 15.5 дБ.

Ключові слова: сегментарні діелектричні резонатори, антена кругового огляду, моди шепочучої галереї.